

NOTE: 1
 DESIGN CODE:
 NS-EN 13445

NOTE: 2
 TECHNICAL CLASSIFICATION:
 Article Type: 003-Valve Stabs
 Main Group: 3.03. Ø55-Valvestab
 Intermediate Group: 3.12.02. Receptacle
 Sub Group: 3.12.69.3. Triple

NOTE: 3
 INTERFACE INFORMATION:
 Pressure Rating Bar: 250
 Design Water Depth:
 Material: Long Term Use
 Weight: 14,4 kg
 Volume: 1,86 dm³
 Submerged Weight: 12,52 kg
 Surface Area: 3712 cm²
 Hydraulic: 1/2" BSP
 Mechanical: N/A
 Electrical: N/A
 Com. & Protocol: N/A

NOTE: 4
 SPAREPARTS:
 BB1690

NOTE: 5
 ADDITIONAL INFORMATION:
 To be connected to CP System for long term submersion

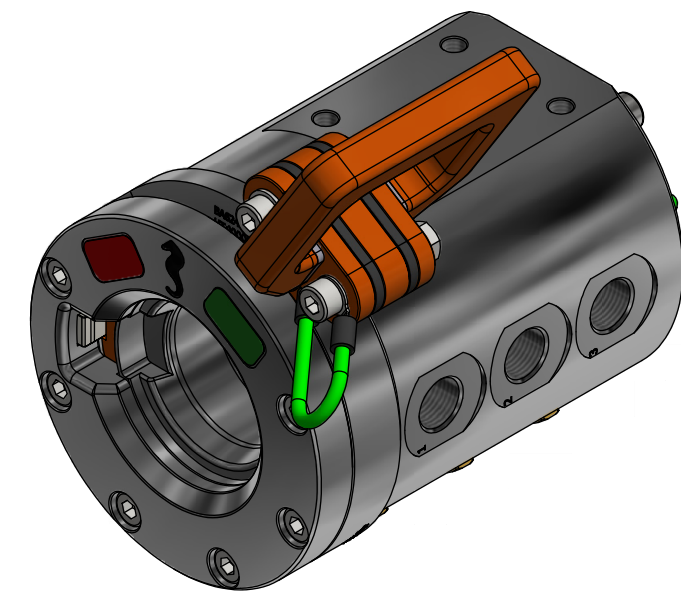

FOR INFORMATION ONLY

05	28.12.2018	2-IFT (Issued for Tender)		WTJ	LGH	WTJ
04	15.8.2016	9-IFU (Issued for Use)		WTJ	LGH	WTJ
03	16.2.2016	9-IFU (Issued for Use)		WTJ	HNJ	WTJ
02	29.1.2015	9-IFU (Issued for Use)		WTJ	LGH	WTJ
Rev.	Date	Reason for issue	Revision change	Made	Chk'd	Appr.



Dwg Scale: NTS	Drawing title: Ø55 TP VStab Rec 250Bar Long Term Use Man BSP
Dwg Proj: ☐	1/2"
Dwg Format: A3	Drawing number: BA6239
	Rev: 05